

KOMATSU

WA
380

Preliminary



WASTEHANDLER

WA380-5

WHEEL LOADER

FLYWHEEL
HORSEPOWER
140 kW 187 HP

OPERATING WEIGHT
20.500 kg

BUCKET VOLUME
4,5 m³

AT A GLANCE

The WA380-5 Waste-handler is based on the WA380-5 wheel loader in the new 5-Star-Loaders series, and guarantees maximum availability even in the most adverse conditions. It is fitted with robust protection and safety equipment, thus providing perfect protection for both operator and machine. Particular attention is also paid to operator comfort in the new Komatsu „SpaceCab™“, with air-conditioning and the high-level intake for cabin air. Simple handling, reliability and comprehensive safety measures make this machine the ideal tool for use in the waste disposal industry, e.g. in transfer stations, waste disposal plants, or at landfill sites.

Wear-resistant heavy duty **mulch grab bucket** with bolt-on cutting edge.

Bucket cylinder protection and **enclosed hydraulic pipework** for the lift cylinders ensure perfect protection for the working hydraulics. The **third hydraulic control circuit** is standard equipment.

Front windscreen safety pressure springs is easily opened windscreen. Such important details grilles for the working lights are



The **5** Star Loader

Cut-resistant L5-industrial tyres with special **valve protection**.

WA380-5

Wheel Loader

FLYWHEEL HORSEPOWER

140 kW 187 HP

OPERATING WEIGHT

20,500 kg

BUCKET VOLUME

4,5 m³

Optional factory equipment: **High-Lift boom** or **high dump bucket**. Easy loading of high-sided lorries or containers.



Overhead engine air intake

Special protective grilles for engine intake air guarantee problem-free operation.



grille with gas-
ed for cleaning the
rails as protective
ails as protective
also not forgotten.

The engine compartment is sealed all round to protect the powerful but economical Komatsu **low-emission engine**.

Hydraulic cylinder protection

The bucket cylinder is protected from damage.



Armoured

front-axle differential housing, fold-down drive-shaft protector and underbody armour protect the machine from below.



Foldable front safety grille

No compromising the field of vision, and makes maintenance easier as well.



Articulation pivot protection

Prevents waste accumulating and removes a potential fire hazard.



Self-cleaning radiator
for easier maintenance.

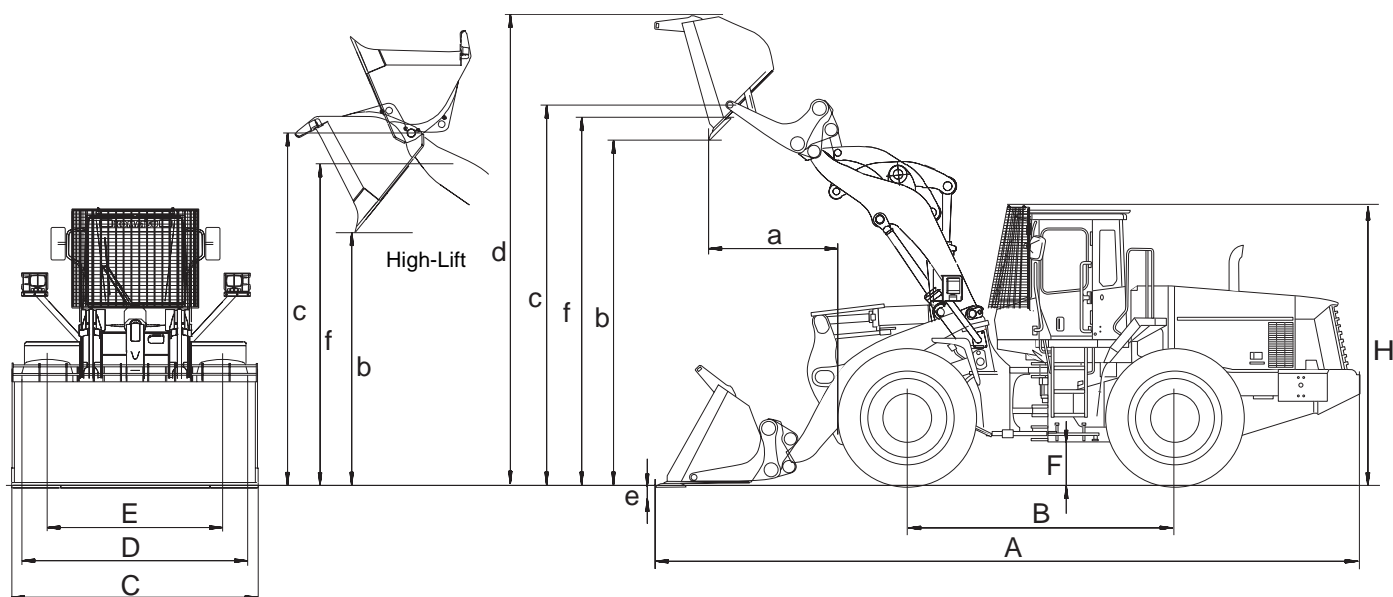

Measurements and working specifications

Bucket type/Kinematic		High dump bucket	High-Lift boom
Bucket capacity (heaped, ISO 7546)	m ³	4,5	4,5
Material Density	t/m ³	1,0	1,05
Bucket weight without teeth	kg	2.700	2.000
Static tipping load, straight	kg	13.940	11.435
Static tipping load, 40° articulated	kg	12.250	10.628
Break-out force hydraulic	kN	143,8	143,8
Lifting capability hydraulic at ground level	kN	169,5	121,8
Operating weight (without add. counterweight)	kg	20.165	20.365
Turning radius at corner of tyres	mm	5.925	5.925
Turning radius at bucket edge	mm	6.872	7.022
a Reach at 45°	mm	1.416	1.445
b Dump height at 45°	mm	4.472	3.340
c Hinge pin Height	mm	4.930	4.680
d Height top edge of bucket	mm	6.252	5.037
e Dig depth	mm	50	30
f Max. loading height at 45°	mm	4.755	4.360
A Overall length, bucket grounded	mm	8.300	8.670
B Wheelbase	mm	3.200	3.200
C Bucket width	mm	3.200	3.200
D Width over tyres	mm	2.805	2.805
E Track width	mm	2.160	2.160
F Ground clearance	mm	500	500
H Overall height	mm	3.650	3.650

Engine

Komatsu SAA6 D114 E-2
Low-emission engine, type diesel/turbo, displacement 8,27 l, flywheel horsepower 140 kW (187 HP) at 2.000 rpm (SAE J1349)

Transmission

Fully automatic 4-gear full-power-shift transmission with kick-down change and gear-hold functions

Steering

Hydrostatic articulated system, max. steering angle 40° either side

Front and rear axles

HD axles with TPD-torque-proportional differential

Operating brakes

Oil bath sealed multiple wet-disc brakes in axle-housings (all-wheel brakes)

Parking brakes

Oil bath sealed multiple wet-disc brake in power distributor gearbox, spring-actuated, opening hydraulically

Hydraulics

2-stage hydraulics, 2-pump system with main and switch pump, 3 control circuits, working pressure max. 210 bar

Specifications apply to tyres 23.5 R25 X-MINE D2. Payload increase through use of additional weights.

Specifications for the WA400/470/480-5 in the Waste-handler version are obtainable on request. Your KOMATSU dealer will be pleased to advise you.

KOMATSU

www.komatsueurope.com