

## Komatsu WA380-8 Wheeled Loading Shovel

**ENGINE POWER**  
143 kW / 192 HP @ 2.100 rpm

**OPERATING WEIGHT**  
18.510 - 19.715 kg

**BUCKET CAPACITY**  
3,1 - 6,5 m<sup>3</sup>

### MEASUREMENTS AND WORKING SPECIFICATIONS

	High-dump bucket	Light material bucket	Waste handling bucket
Sales code	BP 2285	BP 2125	BP 2291
Bucket mount (direct/quick-coupler)	direct	QC	QC
Bucket capacity (heaped, ISO 7546)m <sup>3</sup>	6,0	6,5	5,0
Material density	t/m <sup>3</sup> 0,85	0,8	1,00
Bucket weight	kg 2.420	2.400	1.840
Bucket width	mm 3.000	3.170	3.000
Operating weight*	kg 19.715	19.700	19.135
Rated load	kg 5.100	5.200	5.310
Static tipping load, straight*	mm 12.735	13.135	12.985
Static tipping load, 40° articulated*	mm 11.160	11.455	11.385
Turning radius at bucket edge	mm 7.435	7.520	7.380
A Reach at 45°	mm 2.645	1.640	1.400
a Height top edge of bucket	mm 6.525	6.095	6.045
b Max. loading height at 45°	mm 4.755	3.865	3.865
c Dumping height at 45°	mm 4.405	2.445	2.615

\* with add. counterweight

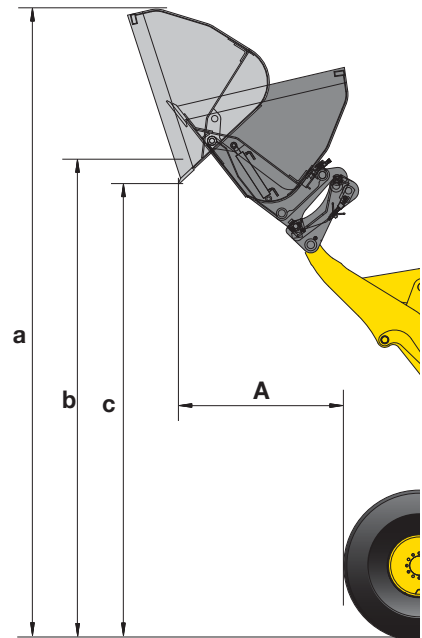

### MEASUREMENTS AND WORKING SPECIFICATIONS

	Fork tines
Sales code	C24
Fork tine length	mm 1.500
A Max. reach at ground level	mm 1.020
B Max. reach	mm 1.680
C Max. reach at max. stacking height	mm 820
a Max. height fork-carrier	mm 4.930
b Hinge pin height	mm 4.095
c Max. stacking height	mm 3.925
d Height of forks at maximum reach	mm 1.885
Max. tipping load, straight	kg 10.250
Max. tipping load, articulated	kg 9.195
Max. payload as per EN 474-3, 80%	kg 7.000
Max. payload as per EN 474-3, 60%	kg 5.375
Weight in working order with fork tines	kg 18.115

