

KOMATSU

WA380-8

EU Stage IV Engine

RIDGWAY Rentals

PLANT RENTAL • HAULAGE • SALES • PARTS • SERVICE

WHEEL LOADER



WA380

ENGINE POWER

143 kW / 192 HP @ 2.100 rpm

OPERATING WEIGHT

18.155 - 19.765 kg

BUCKET CAPACITY

3,2 - 6,5 m³

Walk-Around

WA380-8



ENGINE POWER

143 kW / 192 HP @ 2.100 rpm

OPERATING WEIGHT

18.155 - 19.765 kg

BUCKET CAPACITY

3,2 - 6,5 m³



INCREASED FUEL EFFICIENCY AND ENVIRONMENTAL PERFORMANCE

Powerful and Environmentally Friendly

- EU Stage IV engine
- Komatsu SmartLoader Logic
- E-Light engine mode
- Large-capacity torque converter with standard lock-up
- Adjustable idle shutdown

First-Class Comfort

- New, air-suspended operator seat with integrated EPC lever console
- Large multifunctional monitor
- Low-noise design
- Rear-view camera system

Maximised Efficiency

- High efficiency buckets
- Superior dumping height and reach
- Wide tread and long wheelbase

State-of-the-Art Controls

- Automatic digging system
- Electronic Pilot Control (EPC) standard
- Intelligent gas pedal

Easy Maintenance

- Wide core radiator with auto reverse fan
- Factory fitted automatic lubrication system
- Improved gull-wing type engine doors

KOMTRAX™

- Komatsu Wireless Monitoring System
- 3G mobile communications
- Integrated communication antenna
- Increased operational data and fuel savings



A maintenance program
for Komatsu customers

Powerful and Environmentally Friendly



Komatsu SmartLoader Logic

The WA380-8 provides Komatsu SmartLoader Logic, a fully automatic engine control system. Without interfering with normal operations, this technology acquires data from various sensors in the vehicle and delivers optimal engine torque for each work phase. It limits torque during less demanding operations and reduces fuel usage without decreasing production.

Large-capacity torque converter with standard lock-up

With its large-capacity torque converter, the completely redesigned Komatsu drive train offers optimum efficiency and an unparalleled rimpull-to-weight ratio. By delivering high rimpull at low speeds, it makes child's play of heavy jobs like penetration of dense material such as aggregate. This means higher productivity in V-Shape loading, even in confined spaces.

New E-Light mode

The new E-Light mode is switched on by default for low fuel consumption priority. The engine matches power to the current working phase to achieve higher fuel efficiency. For more fuel economy, the electronically controlled hydraulics pumps for the work and steering system prevent wasted hydraulic flow and deliver the exact amount of oil required for all movements of the machine.

WA380-8

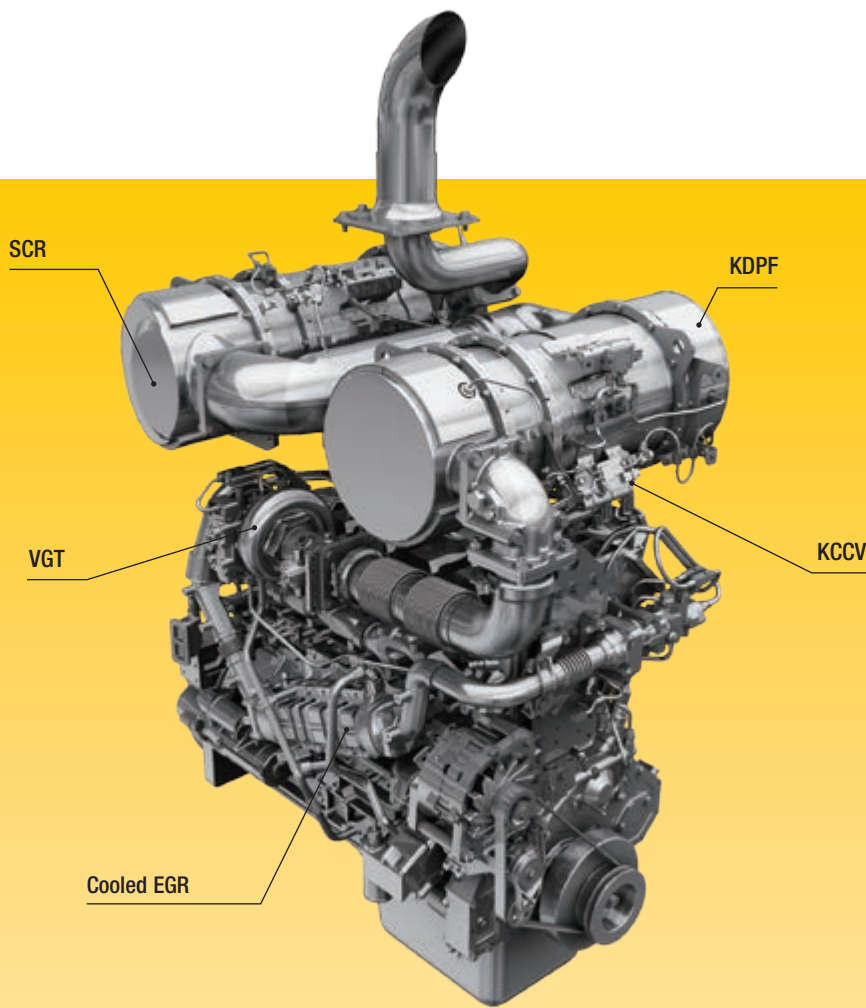

Komatsu EU Stage IV

The Komatsu EU Stage IV engine is productive, dependable and efficient. With ultra-low emissions, it provides a lower environmental impact and a superior performance to help reduce operating costs and lets the operator work in complete peace of mind.

Heavy-duty aftertreatment

The aftertreatment system combines a Komatsu Diesel Particulate Filter (KDPF) and Selective Catalytic Reduction (SCR). The SCR injects the correct amount of AdBlue® into the system at the proper rate to break down NOx into water (H₂O) and non-toxic nitrogen gas (N₂). NOx emissions are reduced by 80% vs. EU Stage IIIB engines.

Exhaust Gas Recirculation (EGR)

Cooled EGR is a technology well-proven in current Komatsu engines. The increased capacity of the EGR cooler now ensures very low NOx emissions and a better engine performance.

Komatsu Closed Crankcase Ventilation (KCCV)

Crankcase emissions (blow-by gas) are passed through a CCV filter. The oil mist trapped in the filter is returned back to the crankcase while the filtered gas is returned to the air intake.

High-Pressure Common Rail (HPCR)

To achieve complete fuel burn and lower exhaust emissions, the heavy-duty High-Pressure Common Rail fuel injection system is computer controlled to deliver a precise quantity of pressurised fuel into the redesigned engine combustion chamber by multiple injections.

Variable Geometry Turbo (VGT)

The VGT provides optimal airflow to the engine combustion chamber under all speed and load conditions. Exhaust gas is cleaner, fuel economy is improved while machine power and performance are maintained.

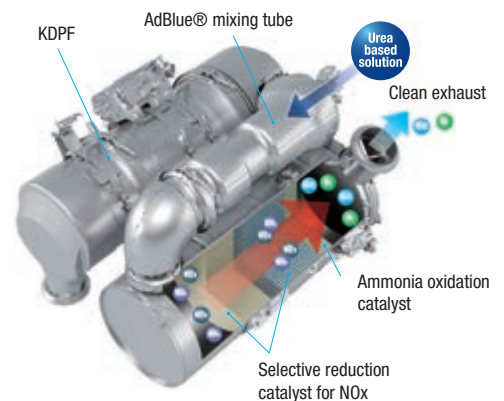

New E-Light engine mode enables increased fuel savings compared to current Economy mode



Adjustable idle shutdown automatically turns off the engine after it idles for a set period of time

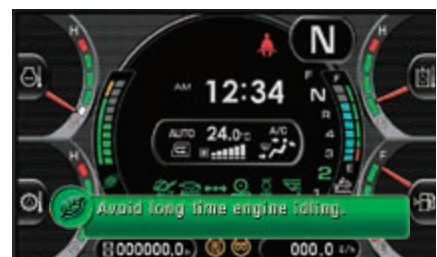

Eco-gauge and an Eco guidance with active recommendations help maximising fuel savings

Maximised Efficiency

Faster Load & Carry

The sequential torque converter lock-up system delivers unbeatable productivity and fuel efficiency in Load & Carry and short distance transport applications. The operator can engage the system from 2nd to 4th gear. It noticeably increases travel speed, particularly when going uphill, thanks to the larger tractive force. It also significantly reduces fuel consumption by eliminating converter losses.

Superior dumping height and reach

The long lifting frame allows an enormous dumping height of 2.790 mm and a reach of 1.235 mm that is just as impressive (with a 3,2 m³ bucket, measured to the tooth tip). With this working range, loading high feeders or trucks becomes easy and fast.

New high efficiency buckets

Soil slips easily from the redesigned bucket, and digging work is more efficient. Operations are easier and productivity improved, especially in combination with the new auto digging system.

Precision control

Komatsu's CLSS hydraulics enables extremely precise control of the work equipment, and ensures that the bucket, boom and hydraulically driven attachments can all move smoothly at the same time. The WA380-8 also features variable-displacement pumps on both the hydraulic and steering systems. These pumps deliver the exact amount of oil required, dramatically improving fuel efficiency.



WA380-8



First-Class Comfort

Increased comfort

In the wide Komatsu SpaceCab™, a standard air-suspended high-back seat, heated for improved comfort and with fully adjustable armrests, is the centre of a comfortable and low-fatigue working environment. High visibility and ergonomic controls further assist to maximise the operator's productivity.

Perfect operator convenience

In addition to the standard radio, the WA380-8 has an auxiliary input for connecting external devices and play music through the cab speakers. Two 12-volt power ports are also incorporated in the cab. Proportional controls are fitted as standard for safe and precise operation of attachments. The cab features large trays and storage boxes for tools and manuals and a hot and cool box.

New automatic digging system

The new automatic digging system actuates the bucket tilt and lifting operations by detecting the sensing pressure applied to the work equipment. The system adapts to different types of material with no human intervention required. Operator fatigue is greatly reduced and ideal load capacity ensured.



WA380-8

State-of-the-Art Controls

New, fully air suspended operator station

The wide spacious cab features a new, fully air suspended operator seat that includes the side consoles mounted together with a high back, fully adjustable, standard heated seat for improved comfort. A seat ventilation is optionally available to maximise comfort.

“By Wire” operating

The Electronic Pilot Control (EPC) lever console is integrated with the seat and can be easily adjusted to suit any operator. The short levers are fingertip controlled for precise and fatigue-free operating, with a no-vibration modulating function for slowing and stopping a lowering bucket. The upper and lower boom cut-out position can be pre-set with a switch.

Intelligent gas pedal

To reduce fuel usage, Komatsu's innovative thrust-sensing gas pedal automatically helps you match the timing of gear shifts to the load.

In heavy-duty work, requiring high rimpull and maximum acceleration, we tend to press heavily on the gas pedal. The WA380-8 anticipates this and shifts up gears as late as possible. In light-duty work, where fuel consumption is a major factor, the operator will intuitively press the gas pedal lightly. Again, the machine anticipates this – and shifts up gears as early as possible to achieve highest fuel efficiency.

Auto-kickdown

The WA380-8 can automatically shift down from F2 to F1 to make operations easier and more productive.

Rear view camera

A standard fitment camera gives an exceptionally clear view of the rear work zone on the wide-screen colour monitor panel. The low profile camera is adjustable and integrated into the engine hood's shape.

EPC-multi-function lever (option)

The EPC-multi-function lever with an integrated forward/reverse switch allows the simplest and most comfortable operation of the equipment. With one hand the driver can simultaneously control the attachment and switch between forward and reverse. The multi-function lever is the perfect choice for earth moving jobs.



Auxiliary input (MP3 jack)



Hot and cool box



EPC-Multifunction lever (option)

Information & Communication Technology



Lower operating costs

Komatsu ICT contributes to the reduction of operating costs by assisting to comfortably and efficiently manage operations. It raises the level of customer satisfaction and the competitive edge of our products.

Large TFT colour monitor

A large user-friendly colour monitor enables safe, accurate and smooth work. Multilingual and with all essential information available at a glance, it features simple and easy-to-operate switches and multifunction keys that provide fingertip access to a wide range of functions and operating information.

Eco guidance

The monitor panel displays instant guidance messages to help promote energy saving, and the Eco-gauge indicates the actual fuel consumption: keep the Eco-gauge in the green zone for better fuel efficiency. To further improve savings, logs can be consulted for operations, Eco guidance and fuel consumption. The information is available in KOMTRAX™ and can be used for operator trainings and jobsite optimisation.



Information at a glance: basic dashboard LCD monitor

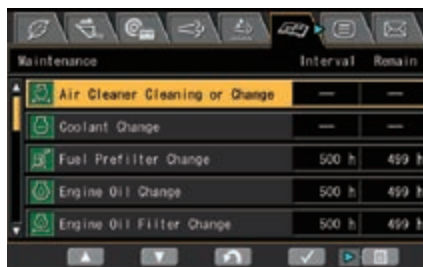

A multifunction monitor displays and controls a wealth of operational and maintenance information

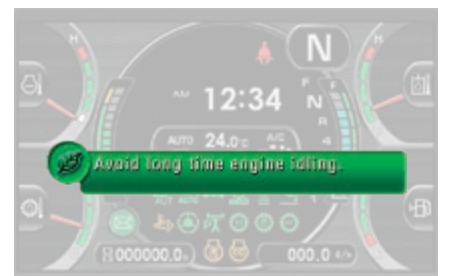

Eco guidance supports energy saving in real time (e.g. avoid long time engine idling)

KOMTRAX™

The way to higher productivity

KOMTRAX™ uses the latest wireless monitoring technology. Compatible on PC, smartphone or tablet, it delivers insightful and cost saving information about your fleet and equipment, and offers a wealth of information to facilitate peak machine performance. By creating a tightly integrated web of support it allows proactive and preventive maintenance and helps to efficiently run a business.



Knowledge

You get quick answers to basic and critical questions about your machines – what they're doing, when they did it, where they're located, how they can be used more efficiently and when they need to be serviced. Performance data is relayed by wireless communication technology (Satellite, GPRS or 3G depending on model) from the machine to a computer and to the local Komatsu distributor – who's readily available for expert analysis and feedback.

Power

The detailed information that KOMTRAX™ puts at your fingertips 24 hours a day, 7 days a week gives the power to make better daily and long-term strategic decisions – at no extra cost. Problems can be anticipated, maintenance schedules customised, downtime minimised and machines kept where they belong: working on the jobsite.

Convenience

KOMTRAX™ enables convenient fleet management on the web, wherever you are. Data is analysed and packaged specifically for effortless and intuitive viewing in maps, lists, graphs and charts. You can foresee eventual maintenance issues and required spare parts, and troubleshoot a problem before Komatsu technicians arrive on site.



Easy Maintenance



Easy access to service points

For easy and safe opening the gull-wing doors are supported by gas springs. The large doors give a convenient access from ground level to all daily service points. With long service intervals and filters collected in a centralised arrangement, machine downtime is reduced to a minimum.

Komatsu CARE™

Komatsu CARE™ is a maintenance program that comes as standard with your new Komatsu machine. It covers factory-scheduled maintenance, performed with Komatsu Genuine parts by Komatsu-trained technicians. Depending on your machine's engine, it also offers extended coverage of the Komatsu Diesel Particulate Filter (KDPF) or the Komatsu Diesel Oxidation Catalyst (KDOC), and of the Selective Catalytic Reduction (SCR). Please contact your local Komatsu distributor for terms and conditions.



Wide core radiator with auto reverse fan

A wide core radiator prevents clogging even when working in a dusty environment. To minimize manual cleaning, a reversible fan blows dust out, automatically or on demand. The "automatic reverse" function allows to set the cleaning length and the time between cleaning to adjust perfectly to the working conditions.

Equipment Management and Monitoring System (EMMS)

The large high resolution monitor panel displays various machine information and allows for multiple settings. The "Operation Records" menu shows records of the average fuel consumption, idling hours, and other features. Abnormality codes are clearly displayed and stored to alert you and simplify troubleshooting. The monitor also provides for advanced monitoring of the system parameters through the Service Mode to aid in troubleshooting and reduce downtime.



AdBlue® tank

The AdBlue® tank is located on the right hand side of the machine behind a ladder for easy access.

Diesel particulate filter regeneration

No interruption or extension of daily work is required to regenerate the diesel particle filter system. Due to its superior Komatsu technology, KDPF regeneration takes place automatically, at any time.



W/A380-8



Basic maintenance screen



Aftertreatment device regeneration screen for the KDPF



AdBlue® level gauge and refill guidance



Tailored Solutions



Working gear division

Komatsu wheel loaders combined with a wide range of genuine Komatsu attachments provide the perfect solution for any industry sector. For special applications our “Working Gear” division offers purpose-built machines and attachments. The tailor made solutions allow high performance and outstanding reliability even under toughest conditions.

Waste handling

We adapt our wheel loaders to the different conditions that exist on waste handling job sites. Along with heavy duty attachments, we offer solutions to protect your machine against damage.

Timber industry

A wide range of options specifically developed for the timber industry are available: wood chip buckets, cameras, as well as various protections and pre-filters.

W/A 380-8

Quality You Can Rely On

Designed and built by Komatsu

The engine, hydraulics, power train, front and rear axles are original Komatsu components. All these components are subject to the highest quality standards right down to the smallest screw. All components are fully co-ordinated with one another, thus offering the maximum efficiency and reliability.

Heavy-duty axles

The heavy-duty axles allow exceptional service life even under the toughest working conditions. The optional limited slip differentials are most suitable for soft and slippery ground like sand or wet soil.

Robust torsion-resistant main frame

The frame design with hinge points far apart guarantees the high stability for the overall construction and reduces bearing stress in the torsional ranges.

Wet multi-disc service brake

The multi-disc service brake is encapsulated and runs in an oil bath. The brake stays clean and operates at low temperature for increased service intervals and a long lifetime.

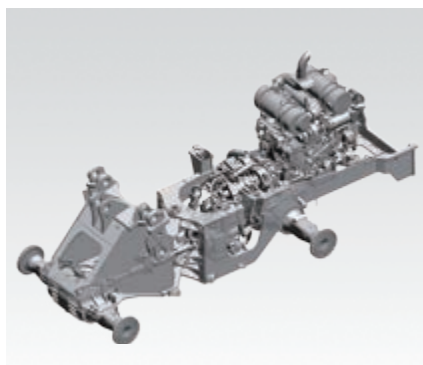

Robust torsion-resistant main frame

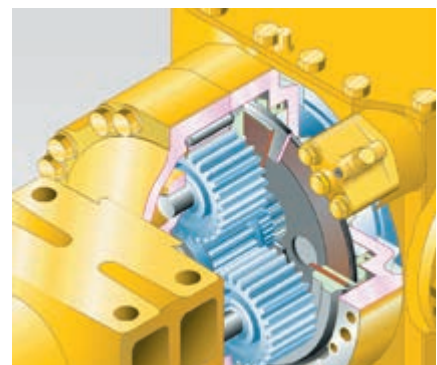

Wet multi-disc service brake

Buckets and Attachments



New high efficiency stockpile buckets

New high efficiency universal buckets

HD wedge type quick-coupler

New high efficiency bucket range

The new Komatsu high efficiency buckets enable easier bucket fill and significantly higher fill factors, contributing to more efficiency and less fuel consumption. They feature a longer bottom for more bucket content, a wider opening for an easier fill and a new rear shape that enables material to flow easily into the bucket. Their rounded sides give them a higher fill factor, and an integrated spill guard protects the bucket linkage. Flush screws (with BOC) reduce resistance when filling and keep material from clogging when dumping.

Hydraulic quick coupler

The WA380-8 can change attachments in a matter of seconds with a market compatible or HD wedge type quick coupler. With the wedge type quick coupler, featuring a unique and innovative design, the offset to the original connection points is reduced to a minimum. Thus, lifting forces remain almost the same compared to a direct mounted bucket.

WA380-8



Specifications

ENGINE

Model	Komatsu SAA6D107E-3
Type	Common rail direct injection, water-cooled, emissionised, turbocharged, after-cooled diesel
Engine power	
at rated engine speed	2.100 rpm
ISO 14396	143 kW / 192 HP
ISO 9249 (net engine power)	142 kW / 191 HP
Max. torque / engine speed	941 Nm / 1.450 rpm
No. of cylinders	6
Bore × stroke	107 × 124 mm
Displacement	6,69 l
Fan drive type	Hydraulic
Alternator	50 A / 24 V
Starter motor	5,5 kW / 24 V
Filter	Main-flow filter with water separator
Air-filter type	Dry-air filter with automatic dust emission and preliminary purification including a dust display

TRANSMISSION

Type	Automatic powershift transmission
Torque converter	One-stage, one-phase, 3-element, with lock-up clutch

SPEEDS IN KM/H (WITH 23.5 R25 TYRES)

Gear	1.	2.	3.	4.
Forward	6,6	11,7	20,9	36,1
with torque converter lock-up	-	12,4	22,5	40,0
Reverse	7,1	12,4	22,3	38,6
with torque converter lock-up	-	13,3	24,1	40,0

CHASSIS AND TYRES

System	4-wheel drive
Front axle	Komatsu HD axle, semi-floating (LSD-differential optional)
Rear axle	Komatsu HD axle, semi-floating, 26° swing angle (LSD-differential optional)
Differential	Spiral bevel gear pair
Final drive	Planetary gear in an oil bath
Tyres	23.5 R25

SERVICE REFILL CAPACITIES

Fuel tank	300 l
Engine oil	23 l
Hydraulic system	142 l
Cooling system	60,6 l
Front axle	40 l
Rear axle	40 l
Torque converter and transmission	54 l
AdBlue® tank	36 l

BRAKES

Operating brakes	Hydraulically actuated, wet multi-disc brakes on all wheels
Parking brake	Wet multi-disc
Emergency brake	Uses the parking brake

HYDRAULIC SYSTEM

Type	Komatsu CLSS (Closed Centre Load Sensing System)
Hydraulic pump	Variable piston pump
Working pressure	320 kg/cm ²
Maximum pump flow	205 l/min
No. of hydraulic/bucket cylinders	2/1
Type	Double-action
Bore diameter × stroke	
Boom cylinder	130 × 713 mm
Bucket cylinder	150 × 535 mm
Hydraulic cycle with rated load bucket filling	
Raise time	5,9 s
Lowering time (empty)	3,3 s
Dumping time	1,8 s

STEERING SYSTEM

System	Articulated frame steering
Type	Completely hydraulic power steering
Steering angle to either side	40°
Steering pump	Variable piston pump
Working pressure	250 kg/cm ²
Pumping capacity	137 l/min
No. of steering cylinders	2
Type	Double-action
Bore diameter × stroke	75 × 442 mm
Smallest turn (outer edge of the tyre 23.5 R25)	6.320 mm

CABIN

Two-door SpaceCab™ in conformity with ISO 3471 with ROPS (roll over protective structure) in conformity with SAE J1040c and FOPS (falling object protective structure) in conformity with ISO 3449. The air-conditioned pressurised cabin is mounted upon hydrobearings and is noise dampened.

ENVIRONMENT

Engine emissions	Fully complies with EU Stage IV exhaust emission regulations
Noise levels	
LwA external	106 dB(A) (2000/14/EC Stage II)
LpA operator ear	68 dB(A) (ISO 6396 dynamic test)
Vibration levels (EN 12096:1997)	
Hand/arm	≤ 2,5 m/s ² (uncertainty K = 0,98 m/s ²)
Body	≤ 0,5 m/s ² (uncertainty K = 0,34 m/s ²)
Contains fluorinated greenhouse gas HFC-134a (GWP 1430). Quantity of gas 1,0 kg, CO ₂ equivalent 1,43 t.	

Dimensions & Performance Figures

MEASUREMENTS AND WORKING SPECIFICATIONS

		High-dump bucket
Sales code		BP 2285
Bucket mount (direct/quick-coupler)		direct
Bucket capacity (heaped, ISO 7546)	m ³	6,0
Material density	t/m ³	0,85
Bucket weight	kg	2.420
Bucket width	mm	3.000
Operating weight	kg	19.765
Rated load	kg	5.100
Static tipping load, straight	mm	12.735
Static tipping load, 40° articulated	mm	11.175
Turning radius at bucket edge	mm	7.435
A Reach at 45°	mm	2.645
a Height top edge of bucket	mm	6.525
b Max. loading height at 45°	mm	4.755
c Dumping height at 45°	mm	4.405

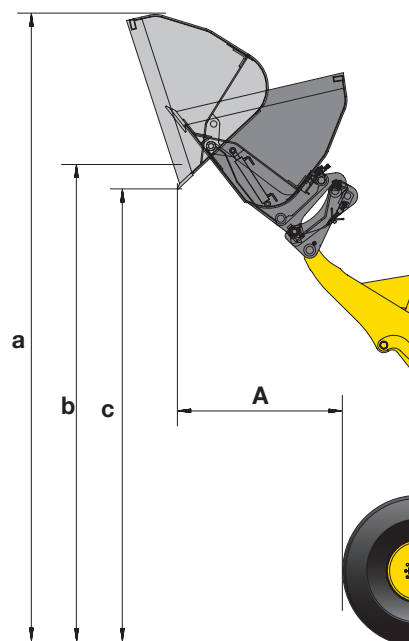

MEASUREMENTS AND WORKING SPECIFICATIONS

		Light material bucket	Waste handling bucket
Sales code		BP 2125	BP 2291
Bucket mount (direct/quick-coupler)		QC	QC
Bucket capacity (heaped, ISO 7546)	m ³	6,5	5,0
Material density	t/m ³	0,8	1,00
Bucket weight	kg	2.400	1.840
Bucket width	mm	3.170	3.000
Operating weight	kg	19.750	19.185
Rated load	kg	5.200	5.311
Static tipping load, straight	mm	13.135	12.985
Static tipping load, 40° articulated	mm	11.470	11.395
Turning radius at bucket edge	mm	7.520	7.380
A Reach at 45°	mm	1.640	1.400
a Height top edge of bucket	mm	6.095	6.045
b Max. loading height at 45°	mm	3.865	3.865
c Dumping height at 45°	mm	2.445	2.615

MEASUREMENTS AND WORKING SPECIFICATIONS

		Fork tines
Sales code		C24
Fork tine length	mm	1.500
A Max. reach at ground level	mm	1.020
B Max. reach	mm	1.680
C Max. reach at max. stacking height	mm	820
a Max. height fork-carrier	mm	4.930
b Hinge pin height	mm	4.095
c Max. stacking height	mm	3.925
d Height of forks at maximum reach	mm	1.885
Max. tipping load, straight	kg	10.270
Max. tipping load, articulated	kg	9.180
Max. payload as per EN 474-3, 80%	kg	7.000
Max. payload as per EN 474-3, 60%	kg	5.370
Weight in working order with fork tines	kg	18.165

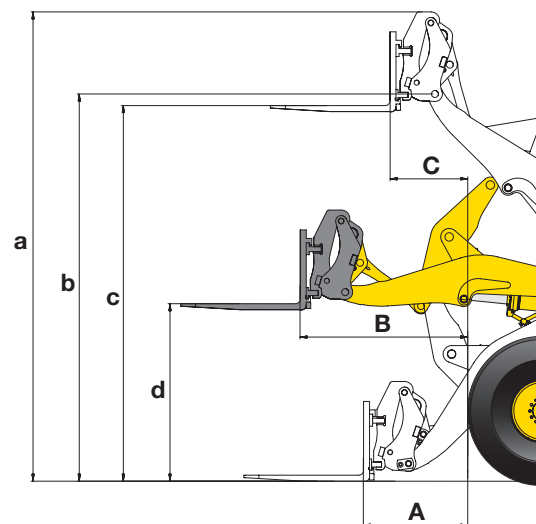

All measurements with tyres 23.5 R25 (XHA) and additional counterweight.

Dimensions & Performance Figures

MEASUREMENTS AND WORKING SPECIFICATIONS

Bucket type		Bucket with raised bottom			
		w. teeth	w. BOC	w/o teeth	w. BOC
Bucket capacity (heaped, ISO 7546)	m ³	3,2	3,35	3,6	3,75
Sales code	3805	C31	C32	C14	C15
Material density	t/m ³	1,85	1,75	1,65	1,55
Bucket weight	kg	1.670	1.780	1.760	1.870
Static tipping load, straight	kg	15.015	14.755	14.925	14.660
Static tipping load, 40° articulated	kg	13.110	12.865	13.025	12.771
Break-out force hydraulic	kN	164	153	156	146
Lifting capability hydr. at ground level	kN	165	161	161	159
Operating weight (without add. counterw.)	kg	18.155	18.270	18.245	18.360
Turning radius at corner of tyres	mm	6.320	6.320	6.320	6.320
Turning radius at bucket edge	mm	7.305	7.365	7.320	7.280
a Reach at 45°	mm	1.235	1.110	1.275	1.154
b Dumping height at 45°	mm	2.790	2.895	2.750	2.855
c Hinge pin height	mm	4.095	4.095	4.095	4.095
d Height top edge of bucket	mm	5.735	5.735	5.810	5.810
e Digging depth	mm	90	120	90	120
f Max. loading height at 45°	mm	3.785	3.785	3.785	3.785
A Overall length, bucket grounded	mm	8.350	8.210	8.405	8.270
B Wheel base	mm	3.030	3.030	3.030	3.030
C Bucket width	mm	2.990	2.990	2.990	2.990
D Width over tyres	mm	2.765	2.765	2.765	2.765
E Track width	mm	2.160	2.160	2.160	2.160
F Ground clearance	mm	455	455	455	455
H Overall height	mm	3.395	3.395	3.395	3.395

All measurements with tyres 23.5 R25 (XHA) and standard counterweight.
 Details of dumping heights and reach to cutting edge or bolt-on cutting edge (BOC) or teeth.

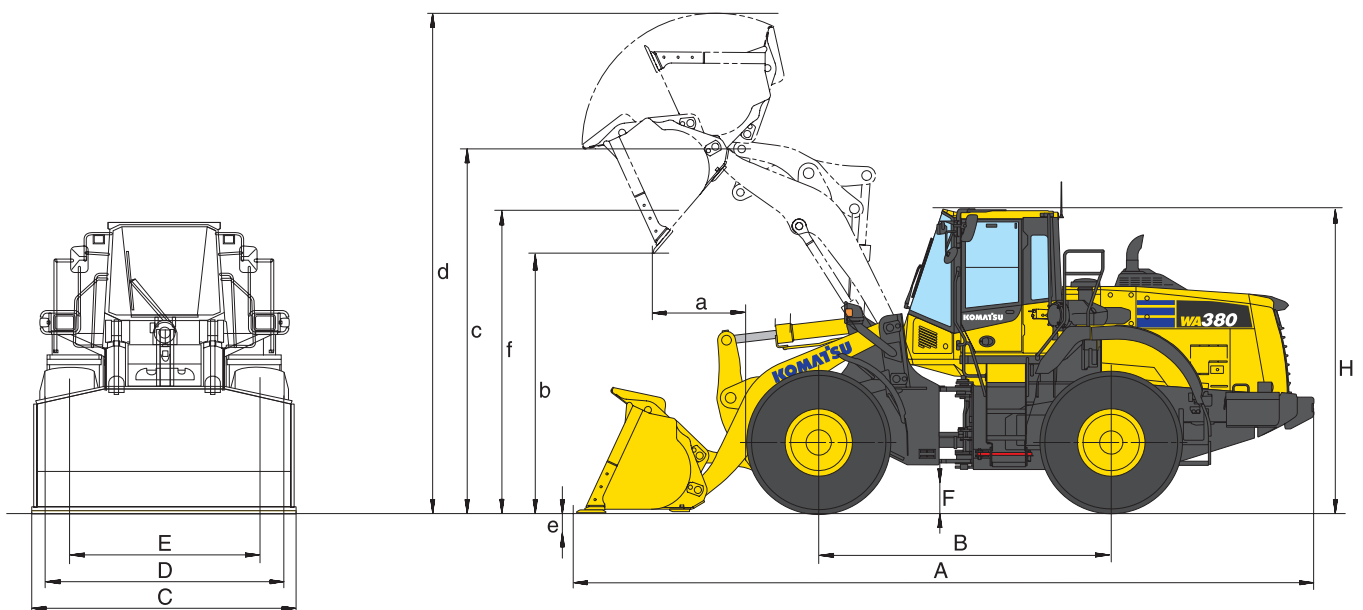

WA380-8

Direct mount (pin-on)

Bucket with flat bottom				Wear protection set (Bucket with flat bottom)	High-lift (with additional counterweight)	Additional counterweight (rear)	Additional counterweight (rear + sides)	Tyres XMINE L5
w. teeth	w. BOC	w. teeth	w. BOC					
3,2	3,35	3,6	3,75	S81 + S83	B24 + A25	A15	A15 + A25	D12
C33	C34	C16	C17					
1,85	1,75	1,65	1,55		- 0,30	+ 0,10	+ 0,10	
1.710	1.820	1.799	1.911	130				
14.920	14.670	14.830	14.566	-150	2.705	+ 825	+1.070	+ 585
13.020	12.785	12.932	12.682	-155	2.490	+ 690	+ 900	+ 510
164	153	156	146		- 10			
164	160	163	158	-1,5	- 40			
18.200	18.310	18.285	18.400	+130	+ 755	+ 325	+ 450	+ 720
6.320	6.320	6.320	6.320					
7.305	7.364	7.320	7.280		+ 285			
1.235	1.110	1.275	1.154		+ 140			- 25
2.795	2.895	2.750	2.854		+ 530			+ 45
4.095	4.095	4.095	4.095		+ 530			
5.735	5.735	5.810	5.810		+ 530			
90	120	90	120		+ 55			
3.805	3.805	3.800	3.805		+ 520			
8.345	8.210	8.405	8.270		+ 595	+ 190	+ 190	
3.030	3.030	3.030	3.030					
2.990	2.990	2.990	2.990					
2.765	2.765	2.765	2.765					+ 35
2.160	2.160	2.160	2.160					
455	455	455	455					+ 45
3.395	3.395	3.395	3.395					+ 45

TYPICAL MATERIAL DENSITY – LOOSE (IN KG/M³)

Basalt	1.960	Gravel, unscreened	1.930	Sandstone	1.510
Bauxite, Kaolin	1.420	Gravel, dry	1.510	Slate	1.250
Earth, dry, ex store	1.510	Gravel, dry, 6-50 mm	1.690	Slag, broken	1.750
Earth, wet, excavated	1.600	Gravel, wet, 6-50 mm	2.020	Stone, crushed	1.600
Gypsum, broken	1.810	Sand, dry, loose	1.420	Clay, natural	1.660
Gypsum, crushed	1.600	Sand, damp	1.690	Clay, dry	1.480
Granite, broken	1.660	Sand, wet	1.840	Clay, wet	1.660
Limestone, broken	1.540	Sand and clay, loose	1.600	Clay and gravel, dry	1.420
Limestone, crushed	1.540	Sand and gravel, dry	1.720	Clay and gravel, wet	1.540

BUCKET SELECTION GUIDE

115 100 95%

 Bucket fill factor

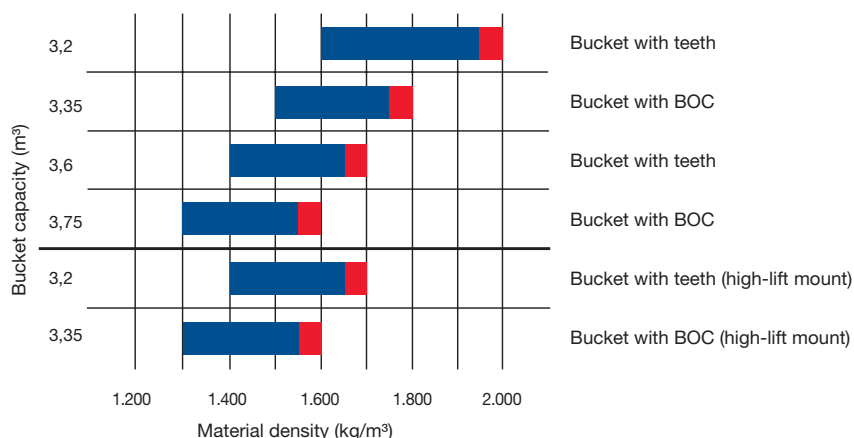

Dimensions & Performance Figures

MEASUREMENTS AND WORKING SPECIFICATIONS

Bucket type		Bucket with raised bottom			
		w. teeth	w. BOC	w/o teeth	w. BOC
Bucket capacity (heaped, ISO 7546)	m ³	3,2	3,35	3,6	3,75
Sales code	3805	C71	C72	C74	C75
Material density	t/m ³	1,70	1,60	1,50	1,45
Bucket weight	kg	1.545	1.655	1.635	1.745
Static tipping load, straight	kg	13.710	13.470	13.685	13.425
Static tipping load, 40° articulated	kg	11.915	11.685	11.885	11.640
Break-out force hydraulic	kN	132	125	127	120
Lifting capability hydr. at ground level	kN	151	147	150	145
Operating weight (without add. counterw.)	kg	18.570	18.680	18.660	18.770
Turning radius at corner of tyres	mm	6.320	6.320	6.320	6.320
Turning radius at bucket edge	mm	7.380	7.335	7.395	7.355
a Reach at 45°	mm	1.440	1.315	1.485	1.360
b Dumping height at 45°	mm	2.585	2.690	2.545	2.645
c Hinge pin height	mm	4.095	4.095	4.095	4.095
d Height top edge of bucket	mm	5.935	5.935	6.010	6.010
e Digging depth	mm	90	120	90	120
f Max. loading height at 45°	mm	3.785	3.785	3.785	3.785
A Overall length, bucket grounded	mm	8.635	8.500	8.695	8.560
B Wheel base	mm	3.030	3.030	3.030	3.030
C Bucket width	mm	2.990	2.990	2.990	2.990
D Width over tyres	mm	2.765	2.765	2.765	2.765
E Track width	mm	2.160	2.160	2.160	2.160
F Ground clearance	mm	455	455	455	455
H Overall height	mm	3.395	3.395	3.395	3.395

All measurements with tyres 23.5 R25 (XHA) and standard counterweight.
 Details of dumping heights and reach to cutting edge or bolt-on cutting edge (BOC) or teeth.
 * With additional counterweight A23

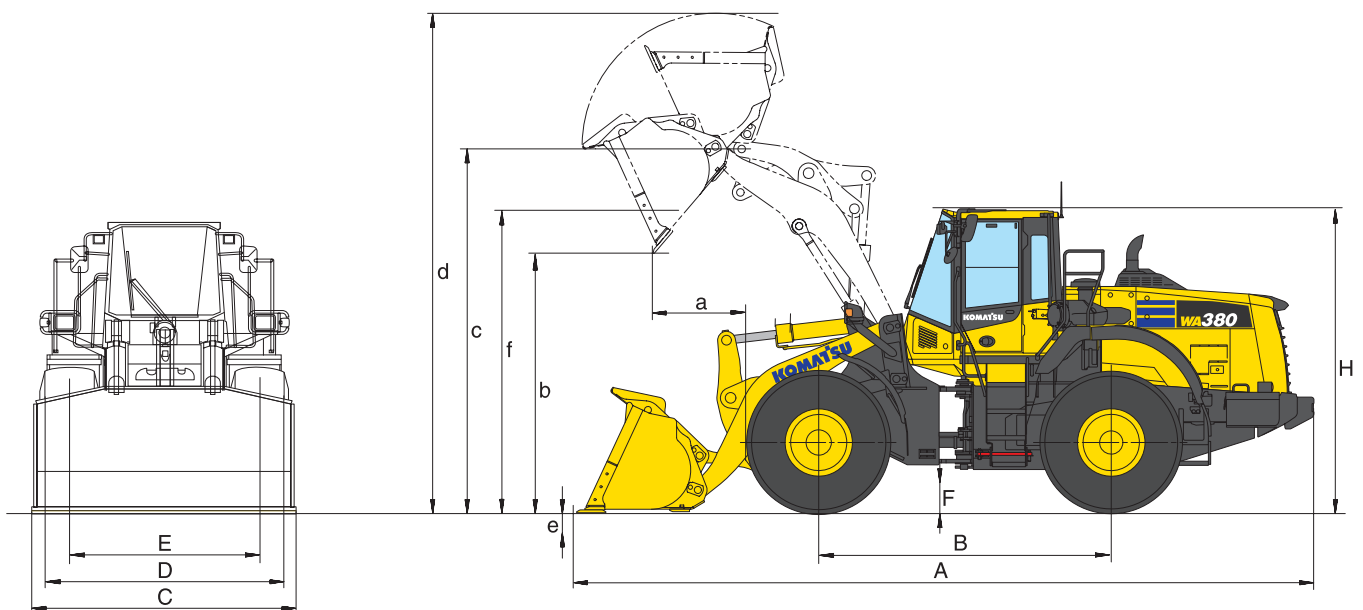

WA380-8

Quick coupler mount

Bucket with flat bottom				Wear protection set (Bucket with flat bottom)	High-lift (with additional counterweight)	Additional counterweight (rear)	Additional counterweight (rear + sides)	Tyres XMINE L5
w. teeth	w. BOC	w. teeth	w. BOC					
3,2	3,35	3,6	3,75	S81 + S83	B24 + A25	A15	A15 + A25	D12
C78	C79	C76	C77		- 0,30	+ 0,10	+ 0,10	
1,70	1,60	1,50	1,45					
1.615	1.725	1.705	1.815	130				
13.645	13.405	13.550	13.310	-150	2.705	+ 825	+1.070	+ 585
11.850	11.620	11.755	11.530	-155	2.490	+ 690	+ 900	+ 510
132	125	127	120		- 10			
150	146	149	144		-1,5	- 40		
18.640	18.755	18.730	18.840	+130	+ 755	+ 325	+ 450	+ 720
6.320	6.320	6.320	6.320					
7.380	7.335	7.395	7.355		+ 285			
1.440	1.315	1.485	1.360		+ 140			- 25
2.585	2.690	2.545	2.645		+ 530			+ 45
4.095	4.095	4.095	4.095		+ 530			
5.575	5.575	6.010	6.010		+ 530			
90	120	90	120		+ 55			
3.805	3.805	3.805	3.805		+ 520			
8.638	8.500	8.698	8.560		+ 595	+ 190	+ 190	
3.030	3.030	3.030	3.030					
2.990	2.990	2.990	2.990					
2.765	2.765	2.765	2.765					+ 35
2.160	2.160	2.160	2.160					
455	455	455	455					+ 45
3.395	3.395	3.395	3.395					+ 45

TYPICAL MATERIAL DENSITY – LOOSE (IN KG/M³)

Basalt	1.960	Gravel, unscreened	1.930	Sandstone	1.510
Bauxite, Kaolin	1.420	Gravel, dry	1.510	Slate	1.250
Earth, dry, ex store	1.510	Gravel, dry, 6-50 mm	1.690	Slag, broken	1.750
Earth, wet, excavated.....	1.600	Gravel, wet, 6-50 mm.....	2.020	Stone, crushed	1.600
Gypsum, broken.....	1.810	Sand, dry, loose	1.420	Clay, natural	1.660
Gypsum, crushed.....	1.600	Sand, damp.....	1.690	Clay, dry	1.480
Granite, broken.....	1.660	Sand, wet	1.840	Clay, wet.....	1.660
Limestone, broken.....	1.540	Sand and clay, loose	1.600	Clay and gravel, dry.....	1.420
Limestone, crushed.....	1.540	Sand and gravel, dry	1.720	Clay and gravel, wet.....	1.540

BUCKET SELECTION GUIDE

115 100 95%
 Bucket fill factor

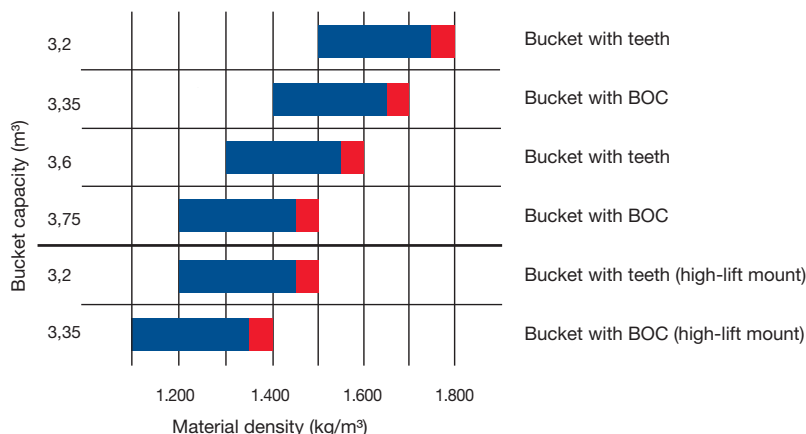

Standard and Optional Equipment

ENGINE

Komatsu SAA6D107E-3 turbocharged common rail direct injection diesel engine	●
EU Stage IV compliant	●
Engine mode selection system: Power, Economy, E-Light	●
Komatsu SmartLoader Logic	●
Adjustable idle shutdown	●
Auto-deceleration function	●
Fuel filter with water separator	●
Batteries 2 × 180 Ah / 2 × 12 V	●

CHASSIS AND TYRES

Heavy-duty axles	●
Front fenders	●
Full rear fenders	●
Brake cooling system (front & rear)	●
Limited-slip differential (LSD) front and rear	○
Tyres 23.5 R25 L2, L3, L5	○

HYDRAULIC SYSTEM

2-spool main control valve	●
EPC fingertip control, two levers, including:	
- Bucket stop modulation	●
- Boom stop pre-setting	●
- Automatic dig function	●
Automatic return-to-dig	●
3-spool main control valve	○
EPC fingertip control, three levers	○
EPC 1-lever (Multi-function lever) with sliding proportional control for attachments	○
Biodegradable oil for hydraulic system	○

TRANSMISSION AND BRAKES

Electronically controlled ECMV automatic transmission with mode selector and variable transmission cut-off	●
Transmission shift mode selection system	●
Large-capacity torque converter	●
Torque converter lock-up	●
Auto-kickdown	●

CABIN

Spacious double door driver's cab to DIN/ISO	●
ROPS/FOPS frame according to SAE	●
Heated, high back air suspension seat, console mounted height adjustable arm rests	●
Retractable seat belt	●
Automatic climate control system	●
Multi-function video compatible colour monitor with Equipment Management and Monitoring System (EMMS) and efficiency guidance	●
CD radio w. auxiliary input (MP3 jack)	●
Hot and cool box	●
Heated rear window	●
Rear window wiper	●
Adjustable steering column	●
2 × 12 V power supply	●
Heated, high back air suspension seats with pneumatically adjustable lumbar support, console mounted height adjustable arm rests	○
3-point seat belt	○
Sun roller blind	○

LIGHTING SYSTEM

2 halogen main headlights	●
2 spotlights at front and rear	●
Reversing light	●
Additional lights front and rear	○
LED working lights	○
Xenon working lights	○

SERVICE AND MAINTENANCE

Hydrostat-driven radiator fan with automatic reversing function	●
Wide core radiator	●
KOMTRAX™ – Komatsu wireless monitoring system (3G)	●
Komatsu CARE™ – a maintenance program for Komatsu customers	●
Tool-set	●
Automatic central lubrication	●
Filling tool for central lubrication system	○
Turbo II air pre-cleaner, cyclone type	○

SAFETY EQUIPMENT

Emergency steering system	●
Vandalism protection	●
Back-up alarm	●
Battery main switch	●
Handrails on left/right	●
Rear-view camera system	●
Front screen protective grid	○
Fire extinguisher	○
Beacon light	○
Roof rail	○
Rear view mirror, heated and remote control	○
Optical back-up alarm (strobe light)	○

ATTACHMENTS

High Lift equipment	○
Super High Lift equipment	○
Hydraulic quick-coupler	○
High efficiency buckets with flat or raised bottom	○
High-dump buckets	○
Fork carrier and tines	○
Waste handling buckets	○
Light material buckets	○

OTHER EQUIPMENT

Counterweight	●
Electronically controlled load stabilizer (ECSS II)	●
Special custom colour	○
Add. counterweight rear (325 kg)	○
Add. counterweight rear and side (450 kg)	○
Anti-corrosion specification	○
Waste-handler specification	○
Cold area kit (engine and cab pre-heating)	○

Further equipment on request

- standard equipment
- optional equipment

Your Komatsu partner:

KOMATSU

**Komatsu Europe
International N.V.**

Mechelsesteenweg 586
B-1800 VILVOORDE (BELGIUM)
Tel. +32-2-255 24 11
Fax +32-2-252 19 81
www.komatsu.eu

VENSS05802 03/2017

KOMATSU is a trademark of Komatsu Ltd. Japan.