

KOMATSU

PC45MR-5 PC55MR-5

MINI-EXCAVATOR



PC45/55

ENGINE POWER

29,5 kW / 39,6 HP @ 2.400 rpm

OPERATING WEIGHT

PC45MR-5: 4.950 kg
PC55MR-5: 5.280 kg

BUCKET CAPACITY

PC45MR-5: 0,055 - 0,16 m³
PC55MR-5: 0,055 - 0,18 m³

Walk-Around

PC45MR / 55MR-5



ENGINE POWER

29,5 kW / 39,6 HP @ 2.400 rpm

OPERATING WEIGHT

PC45MR-5: 4.950 kg
PC55MR-5: 5.280 kg

BUCKET CAPACITY

PC45MR-5: 0,055 - 0,16 m³
PC55MR-5: 0,055 - 0,18 m³



INCREASED FUEL EFFICIENCY AND ENVIRONMENTAL PERFORMANCE

Powerful and Environmentally Friendly

- Komatsu fuel-saving technology
- 6 selectable working modes
- Auto-deceleration and idle shutdown
- Dial type fuel control

First-Class Comfort

- Newly designed cab
- Improved operator convenience
- Multi-function monitor with high resolution 3,5" LCD color display
- Multiple accessories around the operator's seat

Maximized Efficiency

- Powertilt option (PC55MR-5)
- Many configurations to suit the job at hand

Safety First

- Neutral position detection system
- Emergency engine stop switch
- Seat belt caution indicator
- Large transport tie down points

Easy Maintenance

- Tilting cab
- Wide opening engine hood
- Maintenance information displayed on the monitor

KOMTRAX

- Komatsu Wireless Monitoring System
- 3G mobile communications
- Integrated communication antenna



Powerful and Environmentally Friendly



Work in tight spaces

The new short-tail PC45/55MR-5 delivers optimal power and digging speed, even in confined spaces where traditional machines can't work: yards, road works, demolition sites, sewers, etc. Sturdy and very stable, it guarantees maximum safety and offers complete operator confidence in any working conditions.

Komatsu CLSS

The CLSS (Closed-centre Load Sensing System) hydraulic circuit guarantees power, speed and perfect control to all movements, including simultaneous ones. The combination of the variable displacement pump and of CLSS allows operators to perform all required movements with maximum efficiency, regardless of the load or rpm.

6 working modes

Depending on the load, operators can conveniently choose between 6 working modes designed to match engine speed, pump delivery and system pressure. Priority can be given either to speed, for more productivity, or to fuel consumption for lighter applications.

PC45MR-5 / 55MR-5

Maximized Efficiency

Customisation

Many configurations are available, so you can choose the perfect machine for the job: long or short arm, rubber, steel or roadliner shoes. The 1 / 2 way auxiliary hydraulic circuit allows the use of a wide range of working tools such as a hammer, a clamshell bucket, an auger etc.

Electronic control system

Fuel consumption on the PC45/55MR-5 is lower by up to 5%. The engine and hydraulic system are optimally controlled according to the operating conditions. The hydraulic loss reductions also help reduce both fuel consumption and environmental impact.

Auto deceleration and auto idle shutdown

Both these functions are provided as standard. Auto-deceleration reduces the engine speed automatically a few seconds after the work equipment lever is moved to the neutral position. The auto idle shutdown automatically stops the engine after a preset time to reduce unnecessary fuel consumption.



Power tilt option (PC55MR-5)



The machine features a dedicated piping for power tilt operation and a single effect hydraulic quick-coupler line. The power tilt installation enhances the versatility of the machine by providing a flexible tool of proven reliability. Piping is routed over the arm for better protection and long lasting design.



First-Class Comfort

An optimal work environment

Despite its compact size, the PC45/55MR-5 offers unequalled comfort. The spacious cab was developed with exceptional care to details, and the work environment is quiet and comfortable. Special attention is given to the operator: ergonomic and dedicated PPC controls, and, in option, an efficient air conditioning and ventilation system to guarantee optimal thermal comfort. A much larger cab door makes cab access a lot easier.

Perfect operator convenience

Proportional controls are fitted as standard for safe and precise operation of attachments. The dial type fuel control makes operation and engine speed adjustment simple. The automatic travel speed shift function allows smooth and efficient operation. Pressing a speed selector button on the blade lever chooses auto 2-speed or fixed 1st speed travel for easy shifting during blade operation. A 12-volt power port is also included in the cab.

New multi-function monitor with more Information

A high-definition 3,5" LCD monitor provides excellent visibility. The high-definition LCD panel is less affected by the viewing angle and surrounding brightness, ensuring excellent visibility. Various alerts and machine information are displayed in a simple format. Useful information such as operation records, machine setting and maintenance data are also provided. The operator can easily switch screens.



PC45MR / 55MR-5

KOMTRAX

The way to higher productivity

KOMTRAX uses the latest wireless monitoring technology. Compatible on PC, smartphone or tablet, it delivers insightful and cost saving information about your fleet and equipment, and offers a wealth of information to facilitate peak machine performance. By creating a tightly integrated web of support it allows proactive and preventive maintenance and helps to efficiently run a business.



Knowledge

You get quick answers to basic and critical questions about your machines – what they're doing, when they did it, where they're located, how they can be used more efficiently and when they need to be serviced. Performance data is relayed by wireless communication technology (Satellite, GPRS or 3G depending on model) from the machine to a computer and to the local Komatsu distributor – who's readily available for expert analysis and feedback.

Power

The detailed information that KOMTRAX puts at your fingertips 24 hours a day, 7 days a week gives the power to make better daily and long-term strategic decisions – at no extra cost. Problems can be anticipated, maintenance schedules customised, downtime minimised and machines kept where they belong: working on the jobsite.

Convenience

KOMTRAX enables convenient fleet management on the web, wherever you are. Data is analysed and packaged specifically for effortless and intuitive viewing in maps, lists, graphs and charts. You can foresee eventual maintenance issues and required spare parts, and troubleshoot a problem before Komatsu technicians arrive on site.



Easy Maintenance



Tilting cab

The wide opening engine bonnets provide a quick access to daily inspection points. The fuel and the hydraulic oil tanks are located under the side bonnet, in a safe and easy-to-reach position. In addition, the cab easily tilts back for major maintenance tasks.

Easier repairs

ORFS hydraulic face seal connectors and DT electrical connectors enhance the machine's reliability and make repairs faster and easier. High durability bushings and a 500 hours engine oil change interval further lower operating costs.



Rear bonnets for quick engine checks, simple inspections, cleaning of the radiators and easy access to the battery



Convenient and save fuel and oil refilling under the front bonnet



Large fuel filter and fuel pre-filter with water separator protect the engine

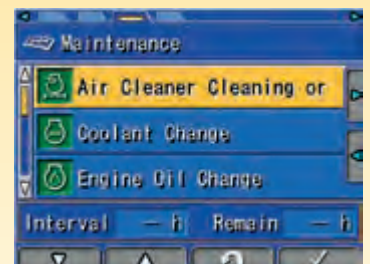

The multifunction monitor panel provides the operator with maintenance and service information.

Highest Reliability and Safety

X-frame

The X-frame ensures maximum stress resistance and optimal stress distribution. Its shape makes the machine a lot more rigid and reliable. In addition, it facilitates the regular undercarriage cleaning operations and the spoils removal process.

Smallest swing radius

The extra-small swing radius with minimum rear protrusion from the tracks (60 mm for PC45MR-5 and 140 mm for PC55MR-5) allows the operator to concentrate on work in confined areas.

Maintenance monitoring

Maintenance and service activities are tracked on the monitor. When the time before a maintenance interval dips below 30 hours, a maintenance reminder light shows on the display.



Secondary engine shut down switch



Seat belt caution and neutral position detection system caution



Hose burst valves on boom and arm cylinders

Specifications

ENGINE

Model	Komatsu 4D88E-6
Type	Water-cooled, 4-cycle direct injection
Engine power	
at rated engine speed	2.400 rpm
ISO 14396	29,5 kW / 39,6 HP
ISO 9249 (net engine power)	28,5 kW / 38,2 HP
No. of cylinders	4
Bore × stroke	88 × 90 mm
Displacement	2.189 cm ³
Max. torque / engine speed	137 Nm / 1.440 rpm
Air filter type	Dry

HYDRAULIC SYSTEM

Type	Komatsu CLSS	
Main pump	2 × variable displacement pump	
Maximum pump flow	53,5 × 2 + 33,8 + 12 l/min	
Max. operating pressure	26,5 MPa (265 bar)	
Hydraulic motors		
Travel	2 × variable displacement motor	
Swing	1 × fixed displacement motor	
Hydraulic cylinders (bore × stroke)		
Boom	90 × 691 mm	
Arm		
PC45MR-5M0	80 × 649 mm	
PC55MR-5M0	85 × 733 mm	
Bucket		
PC45MR-5M0	70 × 580 mm	
PC55MR-5M0	75 × 580 mm	
Boom swing		
PC45MR-5M0	90 × 630 mm	
PC55MR-5M0	95 × 630 mm	
Blade	110 × 140 mm	
Bucket digging force (ISO 6015)		
PC45MR-5M0	3.390 daN (3.460 kg)	
PC55MR-5M0	3.900 daN (3.980 kg)	
Arm crowd force (ISO 6015)		
PC45MR-5M0		
1.375 mm arm	2.160 daN (2.220 kg)	
1.770 mm arm	2.010 daN (2.050 kg)	
PC55MR-5M0		
1.640 mm arm	2.392 daN (2.440 kg)	
2.000 mm arm	2.226 daN (2.270 kg)	

OPERATING WEIGHT (APPR.)

	PC45MR-5M0	PC55MR-5M0
Rubber shoes	4.950 kg	5.280 kg
Roadliner shoes	5.020 kg	5.350 kg
Steel shoes	5.020 kg	5.350 kg

Operating weight, including cabin, specified work equipment, operator, lubricant, coolant, full fuel tank and the standard equipment.

DRIVES AND BRAKES

Steering control	2 levers with pedals giving full independent control of each track
Drive method	Hydrostatic
Hydraulic motors	2 × axial piston motor
Reduction system	Planetary gear
Max. travel speeds	
Lo / Hi	2,6 / 4,6 km/h
Maximum drawbar pull	4.200 daN (4.280 kgf)

UNDERCARRIAGE

Construction	X-frame centre section with box section track frames
Rollers	
Track rollers (each side)	4
Carrier rollers (each side)	1
Shoe width	400 mm
Ground pressure (standard)	0,28 kg/cm ²

SWING SYSTEM

The rotation is operated by means of an orbital hydraulic motor. Single ball-bearing ring with internal, induction hardened toothring. Centralised lubrication of the unit.

Swing speed	9,0 rpm
-------------	---------

BLADE

Type	Electro-welded, single unit structure
Width × height	1.960 × 355 mm
Blade, max. lifting height	430 mm
Blade, max. digging depth	330 mm

SERVICE REFILL CAPACITIES

Fuel tank	65 l
Radiator	8,8 l
Engine oil (refill)	7,5 l
Hydraulic system	55 l

ENVIRONMENT

Engine emissions Fully complies with EU Stage IIIA exhaust emission regulations

Noise levels	
LwA external	96 dB(A) (2000/14/EC Stage II)
LpA operator ear	77 dB(A) (ISO 6396 dynamic test)
Vibration levels (EN 12096:1997)	
Hand/arm	≤ 2,5 m/s ² (uncertainty K = 0,58 m/s ²)
Body	≤ 0,5 m/s ² (uncertainty K = 0,22 m/s ²)

Contains fluorinated greenhouse gas HFC-134a (GWP 1430).
Quantity of gas 0,6 kg, CO₂ equivalent 0,86 t.

DIMENSIONS & WORKING RANGE

		PC45MR-5M0	PC55MR-5M0
Boom length	mm	2.640	2.900
Arm length	mm	1.375 1.770	1.640 2.000
A Overall length	mm	5.220 5.300	5.550 5.615
B Overall height	mm	2.590	2.590
C Overall width	mm	1.960	1.960
D Clearance under counterweight	mm	610	610
E Ground clearance	mm	290	290
F Tail swing radius	mm	1.040	1.120
G Track length on ground	mm	2.000	2.000
H Track length	mm	2.520	2.520
I Track gauge	mm	1.560	1.560
J Shoe width	mm	400	400
K Overall width of upper structure	mm	1.835	1.835
L Distance, swing center to rear end	mm	1.265	1.265
M/N Boom swing angle	°	85 / 50	85 / 50
O Boom offset LH	mm	630	630
P Boom offset RH	mm	880	880
Q Max. digging height	mm	5.500 5.780	5.915 6.180
R Max. dumping height	mm	3.775 4.060	4.200 4.470
S Max. digging depth	mm	3.300 3.705	3.770 4.130
T Max. vertical wall digging depth	mm	2.730 3.145	3.030 3.380
U Max. digging reach	mm	5.735 6.130	6.220 6.570
V Max. digging reach at ground level	mm	5.575 5.980	6.075 6.435
W Min. swing radius	mm	2.290 2.410	2.285 2.390
Min. swing radius at boom swing	mm	1.760 1.860	1.760 1.855

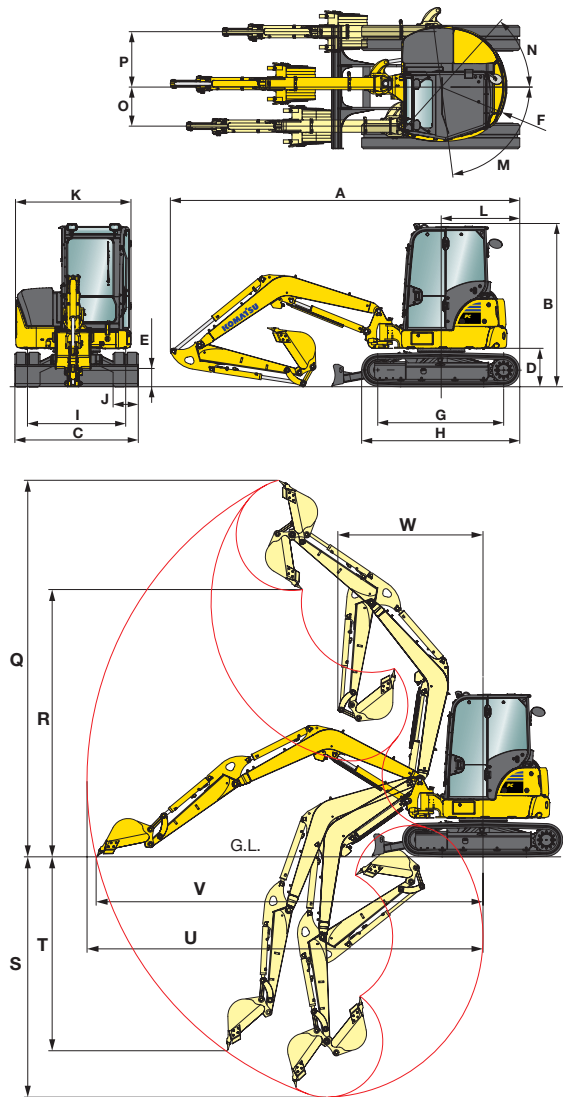

LIFTING CAPACITIES

PC45MR-5M0, rubber shoes, over side, blade up, 109 kg bucket

Arm length	A		Max.	4,0 m	3,0 m	2,0 m
	B					
1.375 mm	4,0 m	kg	890			
	3,0 m	kg	610	740	990	
	2,0 m	kg	510	720	990	
	1,0 m	kg	480	680	990	
	0,0 m	kg	480	650	990	
	-1,0 m	kg	550	640	980	990
1.770 mm	4,0 m	kg	690	750		
	3,0 m	kg	520	730		
	2,0 m	kg	440	730	990	
	1,0 m	kg	410	680	990	
	0,0 m	kg	410	640	990	990
	-1,0 m	kg	460	620	960	990

A Reach from swing centre

B Bucket hook height

Lifting capacities, including bucket, bucket linkage and bucket cylinder

Ratings are based on ISO standard 10567. Rated loads do not exceed 87% of hydraulic lift capacity or 75% of tipping load. Excavators used in object handling operations must comply with the related local regulations and must be equipped with hose burst valves (boom & arm) and an overload warning device in compliance with EN474-5.

- The values marked with an asterisk (*) are limited by the hydraulic capacities.
- Calculations are based on the machine resting on a uniform and firm surface.
- The lifting point is a hypothetical hook placed behind the bucket.

PC55MR-5M0, rubber shoes, over side, blade up, 110 kg bucket

Arm length	A		Max.	4,0 m	3,0 m	2,0 m
	B					
1.640 mm	4,0 m	kg	750	770		
	3,0 m	kg	570	780		
	2,0 m	kg	490	810	990	
	1,0 m	kg	460	760	990	
	0,0 m	kg	460	720	990	
	-1,0 m	kg	510	700	990	990
1.640 mm with Powertilt	4,0 m	kg	500	640		
	3,0 m	kg	460	650		
	2,0 m	kg	380	700	990	
	1,0 m	kg	360	670	960	
	0,0 m	kg	380	620	920	
	-1,0 m	kg	400	610	920	970
2.000 mm	4,0 m	kg	620	600		
	3,0 m	kg	490	630		
	2,0 m	kg	430	810	990	
	1,0 m	kg	400	760	990	
	0,0 m	kg	400	710	990	990
	-1,0 m	kg	430	680	990	990

Standard and Optional Equipment

ENGINE

Komatsu 4D88E-6 water-cooled, 4-cycle direct injection diesel engine	●
EU Stage IIIA compliant	●
Fuel control dial	●
Auto-deceleration function	●
Auto idle shutdown	●
Alternator 12 V / 40 A	●
Starter motor 12 V / 2,3 kW	●
Battery 12 V / 72 Ah	●

HYDRAULIC SYSTEM

6-working mode selection system; power mode, economy mode, breaker mode, attachment power and attachment economy mode, and lifting mode	●
Adjustable PPC wrist control levers for arm, boom, bucket and swing, with proportional control for attachments	●
PPC control lever and pedals for steering and travel	●
Hydraulic line for hammer and for 2-way equipment up to boom and arm (HCU-A)	●
Automatic two-speed travel control	●
Relief valves on service spool	○
Preparation for hydraulic quick-coupler	○
2nd auxiliary hydraulic circuit (HCU-C)	○
3rd auxiliary circuit for hydraulic powertilt and 4th line for hydraulic quick-coupler single effect (PC55MR-5)	○

UNDERCARRIAGE

400 mm rubber shoes	●
400 mm roadliner shoes	○
400 mm steel shoes	○

CABIN

ROPS (ISO 3471) / FOPS (ISO 10262) tilting cab with heating, skylight, pull-up type front window with locking device, lower window, front window wiper with intermittent feature, floor mat	●
Adjustable suspension seat with retractable seat belt	●
Monitor panel 3,5" colour display	●
12 Volt power supply	●
Beverage holder and magazine rack	●
Air conditioning	○
Radio equipment + radio	○

SERVICE AND MAINTENANCE

Multi-function video compatible colour monitor with Equipment Management and Monitoring System (EMMS) and efficiency guidance	●
Battery main switch	●
KOMTRAX – Komatsu wireless monitoring system (3G)	●

WORK EQUIPMENT

Boom	●
Blade	●
1.375 mm digging arm (PC45MR-5)	●
1.640 mm digging arm (PC55MR-5)	●
Boom cylinder protection guard	●
Protection for boom safety valve	●
1.770 mm digging arm (PC45MR-5)	○
2.000 mm digging arm (PC55MR-5)	○

SAFETY EQUIPMENT

Travel acoustic alarm	●
Electric horn	●
Rear-view mirrors (left and right side, right rear)	●
Hose burst valves on boom and arm cylinders	●
Overload warning device	●
Emergency engine stop switch	●
Neutral position detection system	●
Seat belt caution indicator	●
Bucket linkage with lifting eye	○
Blade cylinder safety valve	○

LIGHTING SYSTEM

Working light on boom	●
Two front working lights on cab	●
Rear working light on cab	●
Rotating beacon	○

OTHER EQUIPMENT

Standard colour scheme and decals	●
Parts book and operator manual	●
Gammer adjustable suspension seat (PC55MR-5)	○
Change-over valve on bucket cylinder for clamshell bucket utilization	○
Special waxing	○

ATTACHMENTS

Bucket range (300 - 800 mm)	○
Powertilt unit Lehnhoff (PC55MR-5)	○

The PC45/55MR-5 is equipped in accordance with the safety regulations of the machinery guidelines 89/392 EWG ff and EN474.

- standard equipment
- optional equipment

Your Komatsu partner:

KOMATSU

**Komatsu Europe
International N.V.**

Mechelsesteenweg 586
B-1800 VILVOORDE (BELGIUM)
Tel. +32-2-255 24 11
Fax +32-2-252 19 81
www.komatsu.eu

WENSS08300 06/2017

KOMATSU is a trademark of Komatsu Ltd. Japan.